



DEPARTMENT OF REGULATORY AND ECONOMIC RESOURCES (RER)
BOARD AND CODE ADMINISTRATION DIVISION

NOTICE OF ACCEPTANCE (NOA)

MIAMI-DADE COUNTY
PRODUCT CONTROL SECTION
11805 SW 26 Street, Room 208
Miami, Florida 33175-2474
T (786) 315-2590 F (786) 315-2599
www.miamidade.gov/economy

Renlita Doors North America, LLC
P.O. Box B
Bonham, TX 75418

SCOPE: This NOA is being issued under the applicable rules and regulations governing the use of construction materials. The documentation submitted has been reviewed and accepted by Miami-Dade County RER-Product Control Section to be used in Miami Dade County and other areas where allowed by the Authority Having Jurisdiction (AHJ).

This NOA shall not be valid after the expiration date stated below. The Miami-Dade County Product Control Section (In Miami Dade County) and/or the AHJ (in areas other than Miami Dade County) reserve the right to have this product or material tested for quality assurance purposes. If this product or material fails to perform in the accepted manner, the manufacturer will incur the expense of such testing and the AHJ may immediately revoke, modify, or suspend the use of such product or material within their jurisdiction. RER reserves the right to revoke this acceptance if it is determined by Miami-Dade County Product Control Section that this product or material fails to meet the requirements of the applicable building code.

This product is approved as described herein and has been designed to comply with the Florida Building Code, including the High Velocity Hurricane Zone.

DESCRIPTION: Model S-1000 Floataway Steel and Glass Pivoted Garage Door up to 17'-11" Wide x 8'-10 1/4" High

APPROVAL DOCUMENT: Drawing No. **1K-MIAMI**, titled "s-1000 Floataway Miami-Dade", sheets 1 through 11 of 11, dated 09/16/2016, with revision 3 dated 07/10/2020, prepared by Renlita Doors North America, LLC, signed and sealed by John F. Bonacci, P.E., bearing the Miami-Dade County Product Control Revision stamp with the Notice of Acceptance number and approval date by the Miami-Dade County Product Control Section.

MISSILE IMPACT RATING: Large and Small Missile Impact Resistant

LABELING: A permanent label with the manufacturer's name or logo, manufacturing address, model number, the positive and negative design pressure rating, indicate impact rated if applicable, installation instruction drawing reference number, approval number (NOA), the applicable test standards, and the statement reading 'Miami-Dade County Product Control Approved' is to be located on the door's side track, bottom angle, or inner surface of a panel.

RENEWAL of this NOA shall be considered after a renewal application has been filed and there has been no change in the applicable building code negatively affecting the performance of this product.

TERMINATION of this NOA will occur after the expiration date or if there has been a revision or change in the materials, use, and/or manufacture of the product or process. Misuse of this NOA as an endorsement of any product, for sales, advertising or any other purposes shall automatically terminate this NOA. Failure to comply with any section of this NOA shall be cause for termination and removal of NOA.

ADVERTISEMENT: The NOA number preceded by the words Miami-Dade County, Florida, and followed by the expiration date may be displayed in advertising literature. If any portion of the NOA is displayed, then it shall be done in its entirety.

INSPECTION: A copy of this entire NOA shall be provided to the user by the manufacturer or its distributors and shall be available for inspection at the job site at the request of the Building Official.

This NOA **revises # 21-0504.05** consists of this page 1 and evidence page E-1 & E-2, as well as approval document mentioned above.

The submitted documentation was reviewed by **Carlos M. Utrera, P.E.**



10/24/24

NOA No 24-1007.04
Expiration Date: August 27, 2025
Approval Date: October 31, 2024
Page 1

NOTICE OF ACCEPTANCE: EVIDENCE SUBMITTED

1. Evidence submitted under previous approvals

A. DRAWINGS

1. Drawing No. **1K-MIAMI**, titled “s-1000 Floataway Miami-Dade”, sheets 1 through 11 of 11, dated 09/16/2016, with revision 3 dated 07/10/2020, prepared by Renlita Doors North America, LLC, signed and sealed by John F. Bonacci, P.E.

B. TESTS

1. Test reports on
 - 1) Air Infiltration Test, per FBC, TAS 202-94
 - 2) Uniform Static Air Pressure Test, Loading per FBC TAS 202-94
 - 3) Large Missile Impact Test per FBC, TAS 201-94
 - 4) Cyclic Wind Pressure Loading per FBC, TAS 203-94
 - 5) Forced Entry Test, per FBC, TAS 202-94along with marked-up drawings and installation diagram of 18’x 8’-10” S1000 Operable Curtain Wall, prepared by Intertek, Test Report No. **J5111.01-801-18R2**, dated 10/01/2019, with revision dated 07/16/2020, signed and sealed by Tyler Westerling, P.E.

C. CALCULATIONS

1. Structural steel calculations and static wind pressure analysis prepared by Karins Engineering Group, Inc., dated 04/15/2020, signed and sealed by John F. Bonacci, P.E.

D. QUALITY ASSURANCE

1. Miami-Dade Department of Regulatory and Economic Resources (RER)

E. MATERIAL CERTIFICATIONS

1. Notice of Acceptance No. 17-0808.02 issued to Kuraray America, Inc. for their SentryGlas® (Clear and White) Glass Interlayers, dated on 12/28/2017, expiring on 07/04/2023.

F. STATEMENTS

1. Statement letter of code conformance to the **FBC 6th Edition (2017)** and of no financial interest, issued by Karins Engineering Group, Inc., dated 04/30/2020, signed and sealed by John F. Bonacci, P.E.



Carlos M. Utrera, P.E.
Product Control Unit Supervisor
NOA No 24-1007.04
Expiration Date: August 27, 2025
Approval Date: October 31, 2024

NOTICE OF ACCEPTANCE: EVIDENCE SUBMITTED

2. Evidence submitted under NOA # 21-0504.05 and new

A. DRAWINGS “Submitted under NOA # 21-0504.05”

1. Drawing No. **1K-MIAMI**, titled “s-1000 Floataway Miami-Dade”, sheets 1 through 11 of 11, dated 09/16/2016, with revision 3 dated 07/10/2020, prepared by Renlita Doors North America, LLC, signed and sealed by John F. Bonacci, P.E.

B. TESTS

1. None.

C. CALCULATIONS

1. None.

D. QUALITY ASSURANCE

1. Miami-Dade Department of Regulatory and Economic Resources (RER)

E. MATERIAL CERTIFICATIONS

1. Notice of Acceptance No. **23-0717.30**, issued to Kuraray America, Inc. for their SentryGlas® (Clear and White) Glass Interlayers, dated on 08/31/2023, expiring on 07/04/2028.

F. STATEMENTS

1. Statement letter of code conformance to the 8th edition (2023) of the FBC, and of no financial interest, issued by Karins Engineering Group, Inc., dated 09/19/2024, signed and sealed by John F. Bonacci, PhD, P.E.

“Submitted under NOA # 21-0504.05”

2. Statement letter of code conformance to the 7th edition (2020) of the FBC, and of no financial interest, issued by Karins Engineering Group, Inc., dated 06/14/2021, signed and sealed by John F. Bonacci, PhD, P.E.



Carlos M. Utrera, P.E.
Product Control Unit Supervisor
NOA No 24-1007.04
Expiration Date: August 27, 2025
Approval Date: October 31, 2024

PRODUCT REVISED
as complying with the Florida
Building Code

NOA-No. 24-1007.04

Expiration Date 08/27/2025

By 
Miami-Dade Product Control

DESIGN PRESSURE: +47 PSF/-47 PSF

NOTES:

- DOOR DIMENSIONS ARE FINISHED DOOR SIZE, SEE ELEVATIONS FOR HEIGHT & WIDTH.
- ALL SHOP WELDS TO BE 3/16" OR 1/4" FILLET, FACE WELDS TO BE GROUND SMOOTH.
- COUNTERWEIGHT COVERS TO BE 16 GAUGE ALUMINUM, POWDER COATED TO MATCH DOOR.
- ELECTRICAL: PROVIDE 110V 6A WITHIN 6' OF MOTOR CONTROLLER. SEE PLAN VIEWS FOR LOCATION.
- DOOR OPENING MECHANISM AND ELECTRICAL DEVICES ARE NOT PART OF THIS APPROVAL, THEY MUST BE CERTIFIED BY AN INDEPENDENT AGENCY, IF REQUIRED.
- ALL HSS TUBES ARE ASTM A500, GRADE B (Fy=46,000 psi).
- WALL STRUCTURAL INTEGRITY IS TO BE VERIFIED BY THE ENGINEER OF RECORD.
- LARGE MISSILE IMPACT RESISTANT DOOR

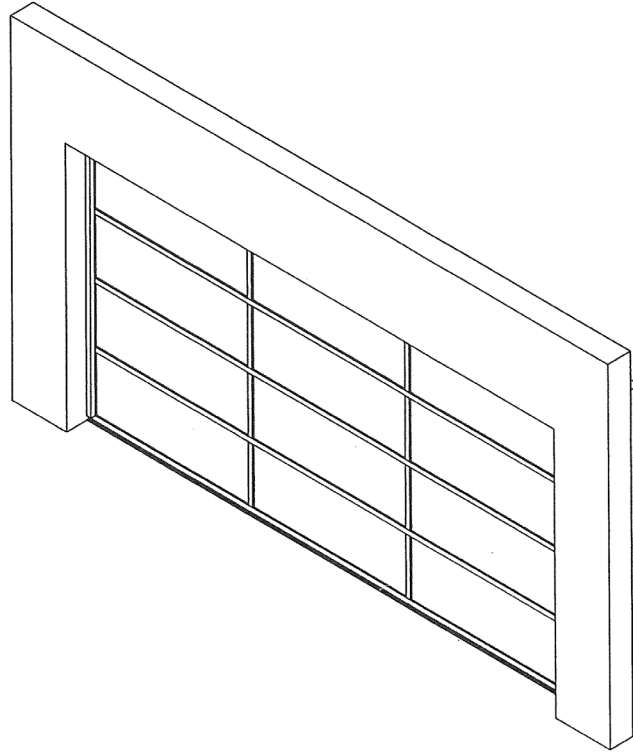

01 OVERALL ISOMETRIC VIEW



FL. Cert. of Auth. # 8371
1626 Ringling Boulevard, Suite 400
Sarasota, FL 34236
(941) 927-8525/ Fax (941) 927-8075
John F Bonacci, PhD, PE
FL. Registration # 63063

SEAL

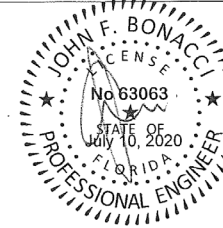

PRODUCT REVISED
as complying with the Florida
Building Code
NOA-No. 21-0504.05

Expiration Date 08/27/2025

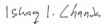
By 
Miami-Dade Product Control

PRODUCT APPROVED
as complying with the Florida
Building Code
NOA-No. 20-0526.06

Approval Date 08/27/2020

By 
Miami-Dade Product Control

| MARK | QTY | TYPE | PRODUCT | WIDTH | HEIGHT | DOOR FRAME & TRACK FINISH | GLAZING BEAD | CLADDING |
|------|-----|-----------|---------|---------|------------|---------------------------|--------------------------|----------------------------------|
| A | 1 | FLOATAWAY | S-1000 | 17'-11" | 8'-10 1/4" | STANDARD COLOR SELECTION | STANDARD COLOR SELECTION | 1 1/8" IGU |
| | | | | | | DRAWN | 9/16/2016 | RENLITA DOORS NORTH AMERICA, LLC |
| | | | | | | DSF | | |
| | | | | | | CHECKED | | |
| | | | | | | QA | TITLE | |
| | | | | | | MFG | | S-1000 FLOATAWAY MIAMI-DADE |
| | | | | | | APPROVED | | SIZE |
| | | | | | | | | DWG NO |
| | | | | | | | | 1K-MIAMI |
| | | | | | | | | REV |
| | | | | | | | | 3 |
| | | | | | | | | SCALE 1:1 |
| | | | | | | | | PAGE 1 OF 11 |

| REVISION HISTORY | | | |
|------------------|-----------------------|----------|----------|
| REV | DESCRIPTION | DATE | APPROVED |
| 3 | REVISED PER MARKUPS | 07/08/20 | SCL |
| 2 | ISSUED FOR PRODUCTION | 09/28/16 | DSF |
| 1 | INITIAL RELEASE | 09/16/16 | DSF |

UNLESS OTHERWISE SPECIFIED
DIMENSIONS ARE IN INCHES.

TOLERANCES

.X=±.050
.XX=±.015
.XXX=±.005

ANGULAR ±.5°

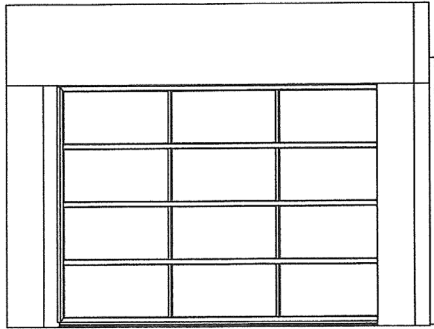

DOOR IN
CLOSED POSITION

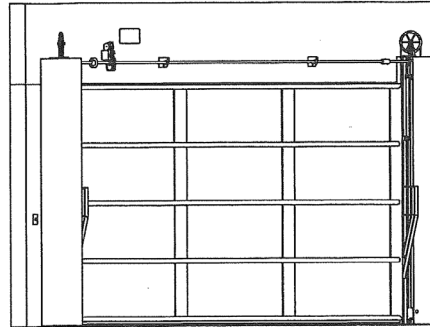

PRODUCT REVISED
as complying with the Florida
Building Code
NOA-No. 24-1007.04
Expiration Date 08/27/2025
By [Signature]
Miami-Dade Product Control

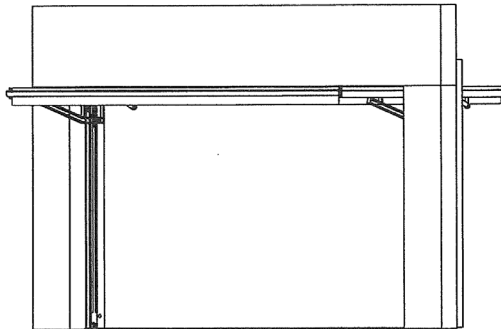

DOOR IN
OPEN POSITION

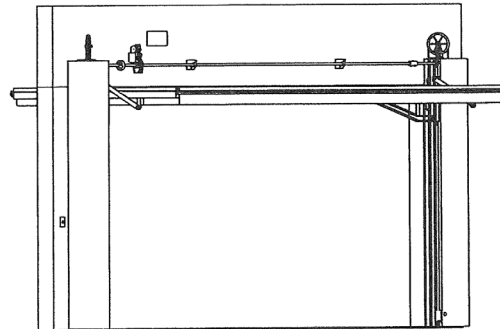

FL. Cert. of Auth. # 8371
1626 Ringling Boulevard, Suite 400
Sarasota, FL 34236
(941) 927-8525/ Fax (941) 927-8075
John F Bonacci, PhD, PE
FL. Registration # 63063

SEAL

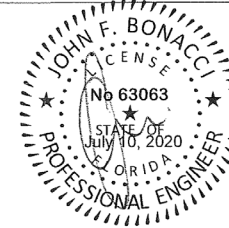

PRODUCT REVISED
as complying with the Florida
Building Code
NOA-No. 21-0504.05
Expiration Date 08/27/2025
By [Signature]
Miami-Dade Product Control

PRODUCT APPROVED
as complying with the Florida
Building Code
NOA-No. 20-0526.06
Approval Date 08/27/2020
By [Signature]
Miami-Dade Product Control

UNLESS OTHERWISE SPECIFIED
DIMENSIONS ARE IN INCHES.

TOLERANCES
X=±.050
.XX=±.015
.XXX=±.005
ANGULAR ±.5°

| | | | |
|----------|-----------|----------------------------------|----------|
| DRAWN | 9/16/2016 | RENLITA DOORS NORTH AMERICA, LLC | |
| DSF | | TITLE | |
| CHECKED | | S-1000 FLOATAWAY MIAMI-DADE | |
| QA | | SIZE | DWG NO |
| MFG | | C | 1K-MIAMI |
| APPROVED | | SCALE 1:1 | REV 3 |
| | | PAGE 2 OF 11 | |

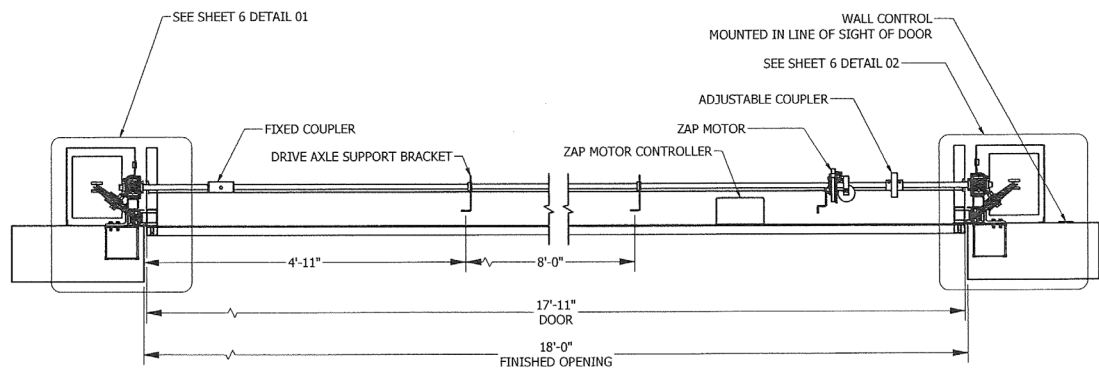

01 DOOR PLAN VIEW



FL. Cert. of Auth. # 8371
 1626 Ringling Boulevard, Suite 400
 Sarasota, FL 34236
 (941) 927-8525/ Fax (941) 927-8075
 John F Bonacci, PhD, PE
 FL. Registration # 63063

SEAL

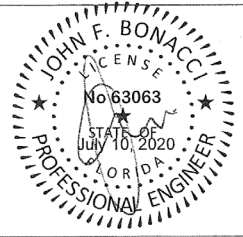

PRODUCT REVISED
 as complying with the Florida
 Building Code
 NOA-No. 24-1007.04

Expiration Date 08/27/2025

By [Signature]
 Miami-Dade Product Control

PRODUCT REVISED
 as complying with the Florida
 Building Code
 NOA-No. 21-0504.05
 Expiration Date 08/27/2025

By [Signature]
 Miami-Dade Product Control

PRODUCT APPROVED
 as complying with the Florida
 Building Code
 NOA-No. 20-0526.06
 Approval Date 08/27/2020

By [Signature]
 Miami-Dade Product Control

UNLESS OTHERWISE SPECIFIED
 DIMENSIONS ARE IN INCHES.
 TOLERANCES
 .X=±.050
 .XX=±.015
 .XXX=±.005
 ANGULAR +.5°

| | | | |
|----------|-----------|----------------------------------|--------------|
| DRAWN | 9/16/2016 | RENLITA DOORS NORTH AMERICA, LLC | |
| DSF | | TITLE | |
| CHECKED | | S-1000 FLOATAWAY MIAMI-DADE | |
| QA | | SIZE | DWG NO |
| MFG | | C | 1K-MIAMI |
| APPROVED | | SCALE 1:1 | REV 3 |
| | | | PAGE 3 OF 11 |

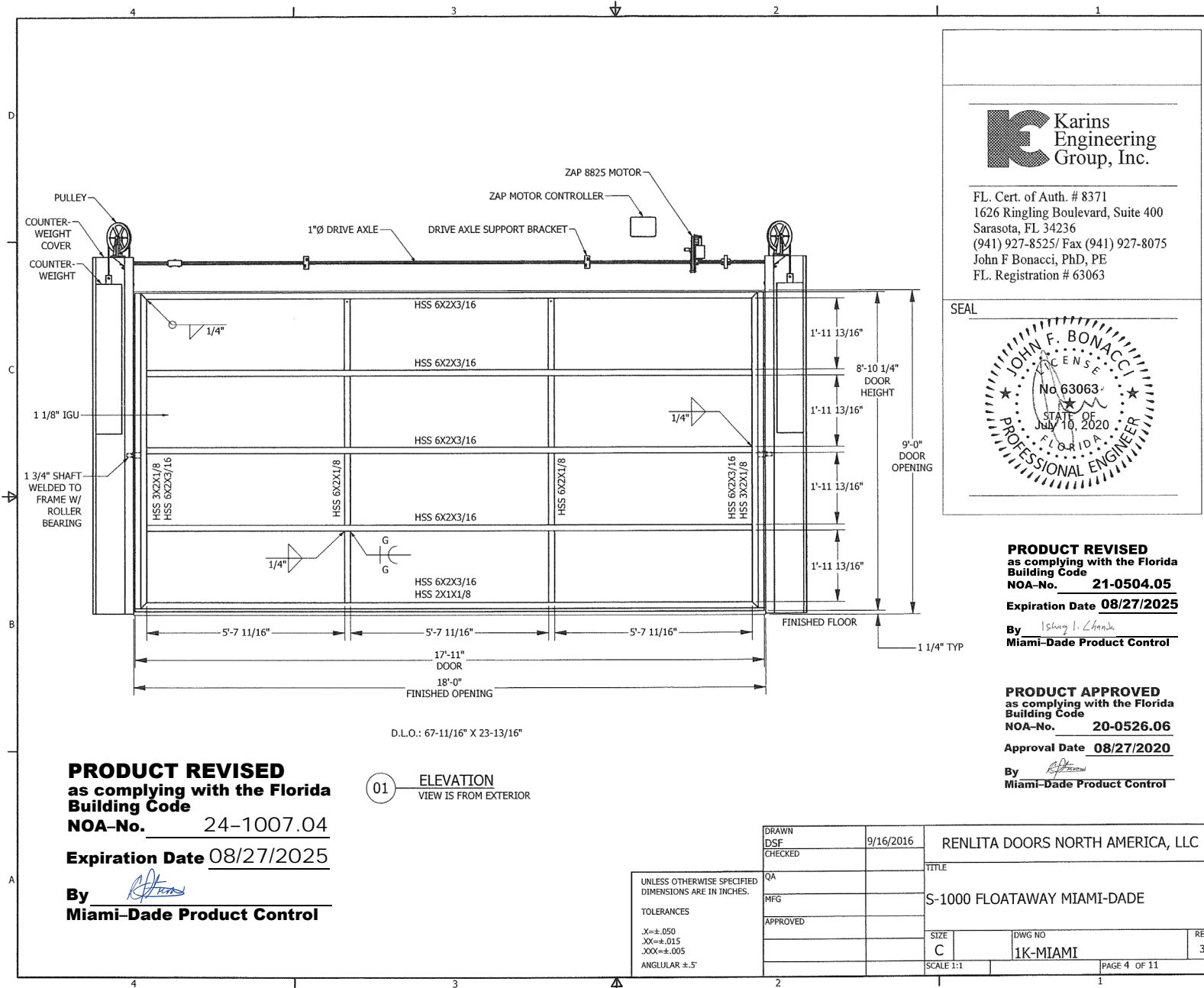

FL. Cert. of Auth. # 8371
 1626 Ringling Boulevard, Suite 400
 Sarasota, FL 34236
 (941) 927-8525/ Fax (941) 927-8075
 John F Bonacci, PhD, PE
 FL. Registration # 63063

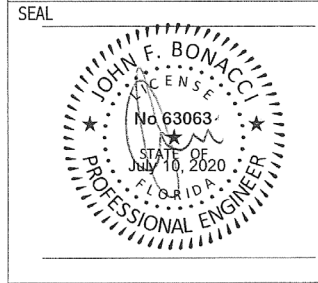

PRODUCT REVISED
 as complying with the Florida
 Building Code
NOA-No. 21-0504.05
Expiration Date 08/27/2025
 By *Isang I. Chank*
Miami-Dade Product Control

PRODUCT APPROVED
 as complying with the Florida
 Building Code
NOA-No. 20-0526.06
Approval Date 08/27/2020
 By *[Signature]*
Miami-Dade Product Control

PRODUCT REVISED
 as complying with the Florida
 Building Code
NOA-No. 24-1007.04
Expiration Date 08/27/2025
 By *[Signature]*
Miami-Dade Product Control

01 ELEVATION
 VIEW IS FROM EXTERIOR

UNLESS OTHERWISE SPECIFIED
 DIMENSIONS ARE IN INCHES.
 TOLERANCES
 .X=±.050
 .XX=±.015
 .XXX=±.005
 ANGULAR ±.5°

| | | | |
|--------------|-----------|----------------------------------|--------------|
| DRAWN DSF | 9/16/2016 | RENLITA DOORS NORTH AMERICA, LLC | |
| CHECKED | | TITLE | |
| QA | | S-1000 FLOATAWAY MIAMI-DADE | |
| MFG | | SIZE | DWG NO |
| APPROVED | | C | 1K-MIAMI |
| | | SCALE 1:1 | REV 3 |
| | | | PAGE 4 OF 11 |

D.L.O.: 67-11/16" X 23-13/16"

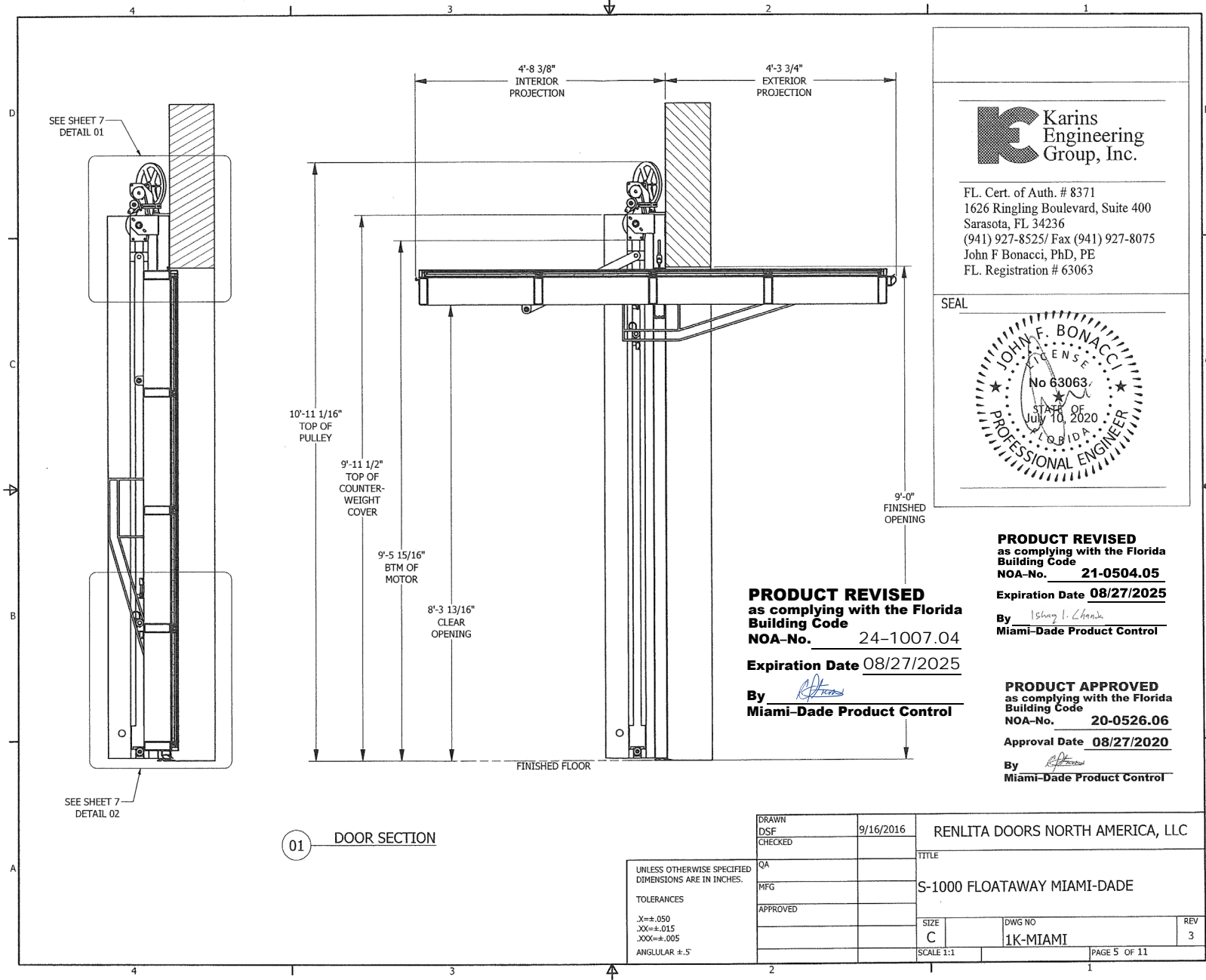

01 DOOR SECTION



FL. Cert. of Auth. # 8371
 1626 Ringling Boulevard, Suite 400
 Sarasota, FL 34236
 (941) 927-8525/ Fax (941) 927-8075
 John F Bonacci, PhD, PE
 FL. Registration # 63063

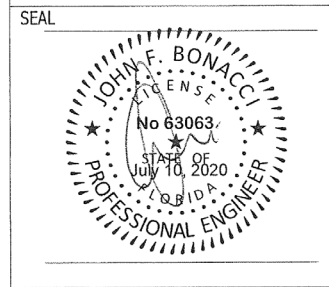

PRODUCT REVISED
 as complying with the Florida
 Building Code
 NOA-No. 24-1007.04
 Expiration Date 08/27/2025
 By *[Signature]*
 Miami-Dade Product Control

PRODUCT REVISED
 as complying with the Florida
 Building Code
 NOA-No. 21-0504.05
 Expiration Date 08/27/2025
 By *[Signature]*
 Miami-Dade Product Control

PRODUCT APPROVED
 as complying with the Florida
 Building Code
 NOA-No. 20-0526.06
 Approval Date 08/27/2020
 By *[Signature]*
 Miami-Dade Product Control

UNLESS OTHERWISE SPECIFIED
 DIMENSIONS ARE IN INCHES.
 TOLERANCES
 .X=±.050
 .XX=±.015
 .XXX=±.005
 ANGULAR ±.5°

| | | | |
|----------|-----------|----------------------------------|--------------|
| DRAWN | 9/16/2016 | RENLITA DOORS NORTH AMERICA, LLC | |
| DSF | | TITLE | |
| CHECKED | | S-1000 FLOATAWAY MIAMI-DADE | |
| QA | | SIZE | DWG NO |
| MFG | | C | 1K-MIAMI |
| APPROVED | | SCALE 1:1 | PAGE 5 OF 11 |
| | | | REV 3 |

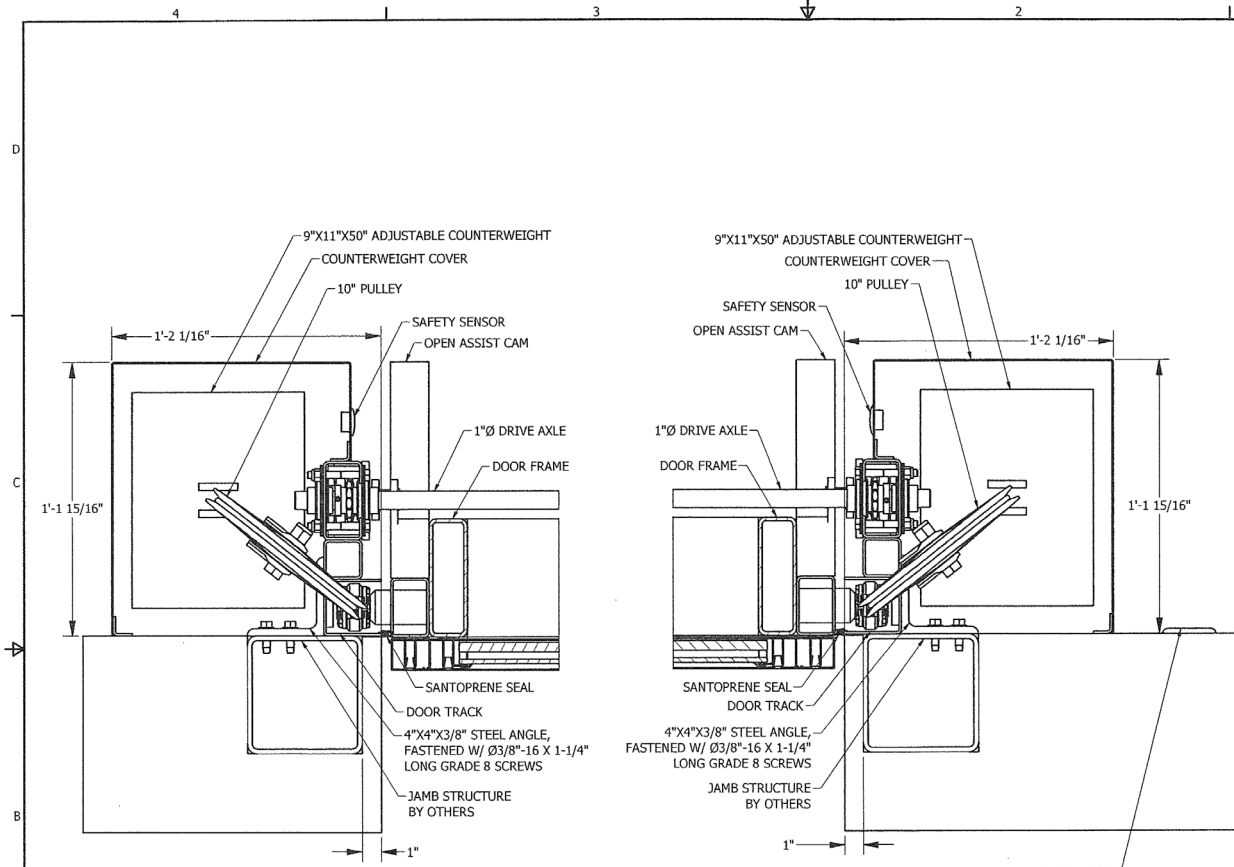

01 JAMB DETAIL

02 JAMB DETAIL

PRODUCT REVISED
 as complying with the Florida
 Building Code
 NOA-No. 24-1007.04
 Expiration Date 08/27/2025
 By [Signature]
 Miami-Dade Product Control



FL. Cert. of Auth. # 8371
 1626 Ringling Boulevard, Suite 400
 Sarasota, FL 34236
 (941) 927-8525/ Fax (941) 927-8075
 John F Bonacci, PhD, PE
 FL. Registration # 63063

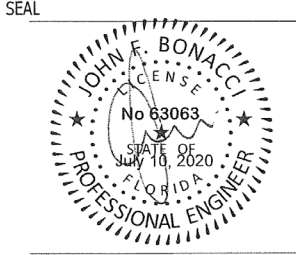

PRODUCT REVISED
 as complying with the Florida
 Building Code
 NOA-No. 21-0504.05
 Expiration Date 08/27/2025
 By [Signature]
 Miami-Dade Product Control

PRODUCT APPROVED
 as complying with the Florida
 Building Code
 NOA-No. 20-0526.06
 Approval Date 08/27/2020
 By [Signature]
 Miami-Dade Product Control

UNLESS OTHERWISE SPECIFIED
 DIMENSIONS ARE IN INCHES.
 TOLERANCES
 .X=±.050
 .XX=±.015
 .XXX=±.005
 ANGULAR ±.5°

| | | | |
|----------|-----------|----------------------------------|----------|
| DRAWN | 9/16/2016 | RENLITA DOORS NORTH AMERICA, LLC | |
| DSF | | TITLE | |
| CHECKED | | S-1000 FLOATAWAY MIAMI-DADE | |
| QA | | SIZE | DWG NO |
| MFG | | C | 1K-MIAMI |
| APPROVED | | SCALE 1:1 | REV 3 |
| | | PAGE 6 OF 11 | |

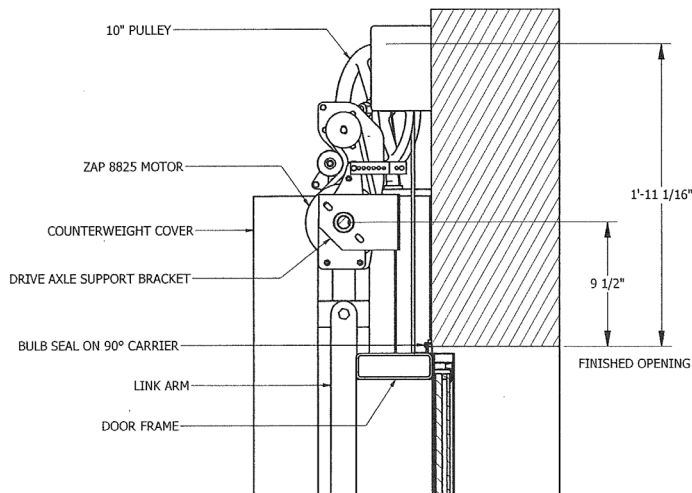

01 DOOR HEAD

PRODUCT REVISED
 as complying with the Florida
 Building Code
 NOA-No. 24-1007.04
 Expiration Date 08/27/2025

By *[Signature]*
Miami-Dade Product Control

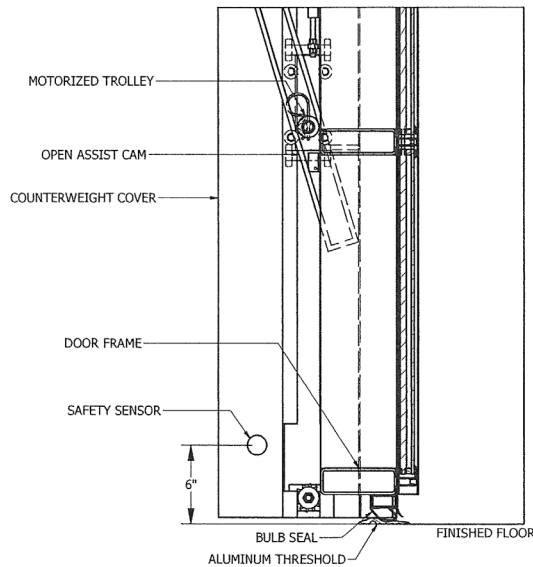

02 DOOR SILL

UNLESS OTHERWISE SPECIFIED
 DIMENSIONS ARE IN INCHES.
 TOLERANCES
 .X=±.050
 .XX=±.015
 .XXX=±.005
 ANGULAR ±.5°

| | | | |
|--------------|-----------|----------------------------------|--------------|
| DRAWN DSF | 9/16/2016 | RENLITA DOORS NORTH AMERICA, LLC | |
| CHECKED | | TITLE | |
| QA | | S-1000 FLOATAWAY MIAMI-DADE | |
| MFG | | SIZE | DWG NO |
| APPROVED | | C | 1K-MIAMI |
| | | SCALE 1:1 | PAGE 7 OF 11 |
| | | | REV 3 |



FL. Cert. of Auth. # 8371
 1626 Ringling Boulevard, Suite 400
 Sarasota, FL 34236
 (941) 927-8525/ Fax (941) 927-8075
 John F Bonacci, PhD, PE
 FL. Registration # 63063

SEAL

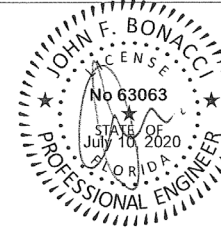

PRODUCT REVISED
 as complying with the Florida
 Building Code
 NOA-No. 21-0504.05
 Expiration Date 08/27/2025

By *[Signature]*
Miami-Dade Product Control

PRODUCT APPROVED
 as complying with the Florida
 Building Code
 NOA-No. 20-0526.06
 Approval Date 08/27/2020

By *[Signature]*
Miami-Dade Product Control

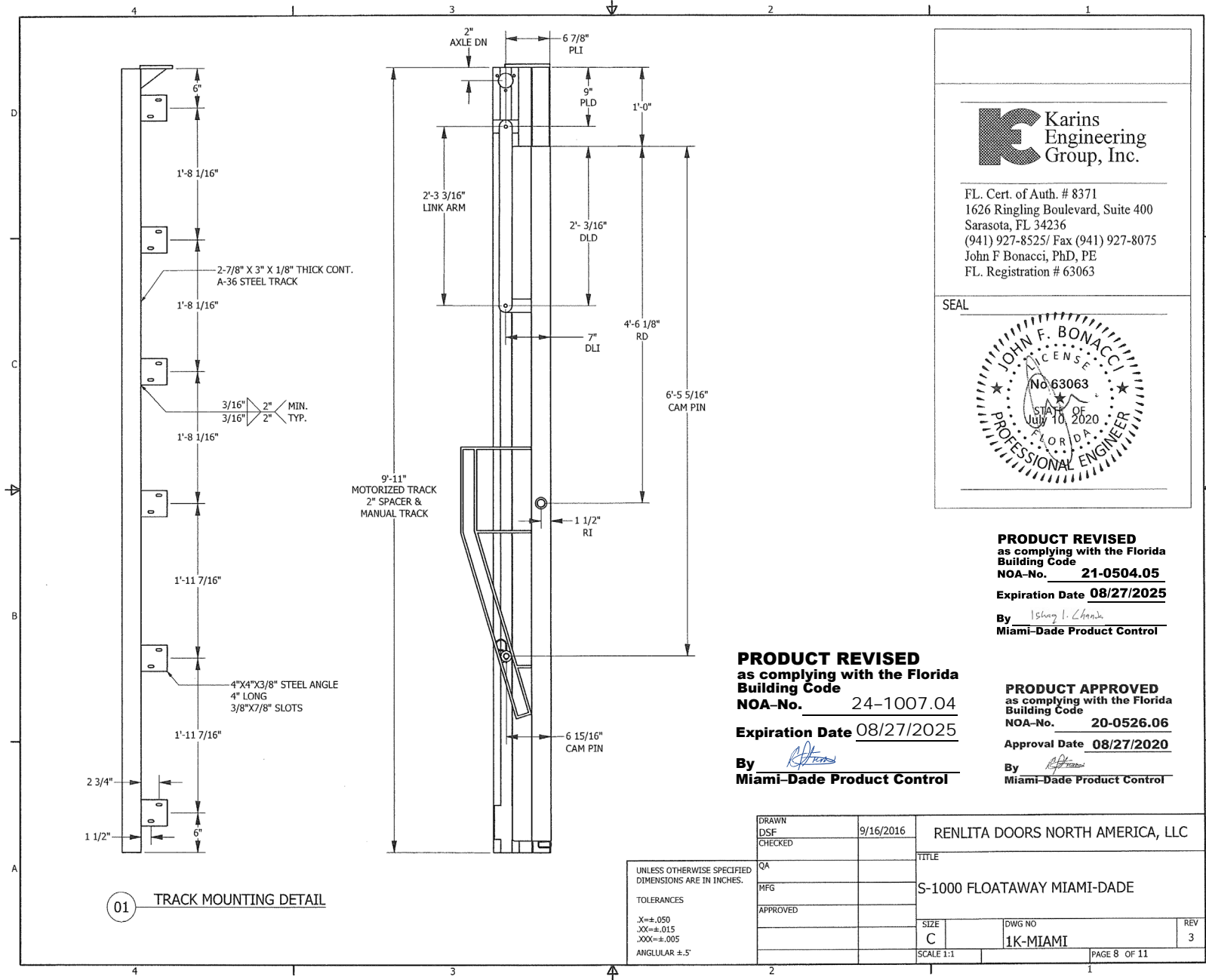

01 TRACK MOUNTING DETAIL



FL. Cert. of Auth. # 8371
 1626 Ringling Boulevard, Suite 400
 Sarasota, FL 34236
 (941) 927-8525/ Fax (941) 927-8075
 John F Bonacci, PhD, PE
 FL. Registration # 63063

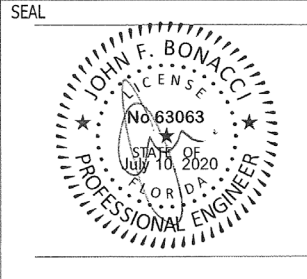

PRODUCT REVISED
 as complying with the Florida
 Building Code
 NOA-No. 21-0504.05
 Expiration Date 08/27/2025
 By Ishay I. Chanin
 Miami-Dade Product Control

PRODUCT REVISED
 as complying with the Florida
 Building Code
 NOA-No. 24-1007.04
 Expiration Date 08/27/2025
 By [Signature]
 Miami-Dade Product Control

PRODUCT APPROVED
 as complying with the Florida
 Building Code
 NOA-No. 20-0526.06
 Approval Date 08/27/2020
 By [Signature]
 Miami-Dade Product Control

| | | | |
|--------------|-----------|----------------------------------|--------------|
| DRAWN DSF | 9/16/2016 | RENLITA DOORS NORTH AMERICA, LLC | |
| CHECKED | | TITLE | |
| QA | | S-1000 FLOATAWAY MIAMI-DADE | |
| MFG | | SIZE | DWG NO |
| APPROVED | | C | 1K-MIAMI |
| | | SCALE 1:1 | PAGE 8 OF 11 |
| | | | REV 3 |

UNLESS OTHERWISE SPECIFIED
 DIMENSIONS ARE IN INCHES.
 TOLERANCES
 X=±.050
 XX=±.015
 XXX=±.005
 ANGULAR ±.5°

PRODUCT REVISED
 as complying with the Florida
 Building Code
 NOA-No. 24-1007.04

Expiration Date 08/27/2025

By *[Signature]*
 Miami-Dade Product Control



FL. Cert. of Auth. # 8371
 1626 Ringling Boulevard, Suite 400
 Sarasota, FL 34236
 (941) 927-8525/ Fax (941) 927-8075
 John F Bonacci, PhD, PE
 FL. Registration # 63063

SEAL

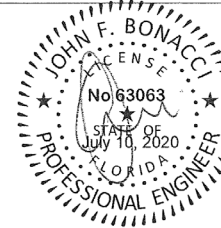

PRODUCT REVISED
 as complying with the Florida
 Building Code

NOA-No. 21-0504.05

Expiration Date 08/27/2025

By *[Signature]*
 Miami-Dade Product Control

PRODUCT APPROVED
 as complying with the Florida
 Building Code

NOA-No. 20-0526.06

Approval Date 08/27/2020

By *[Signature]*
 Miami-Dade Product Control

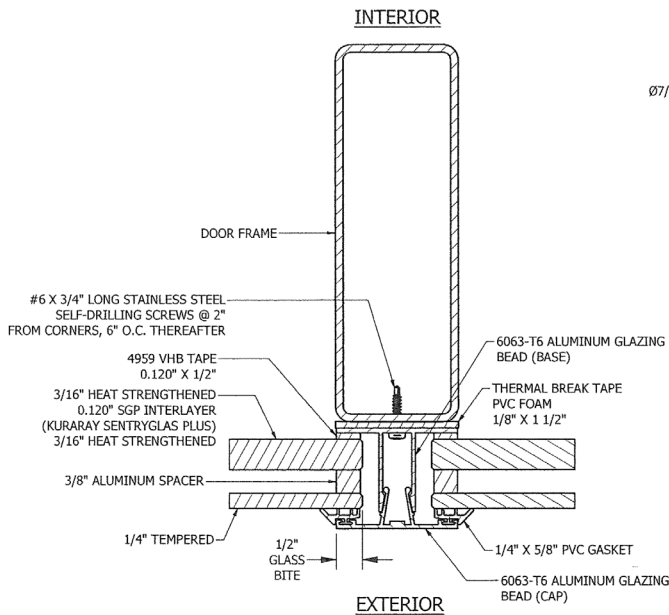

01 GLAZING DETAIL

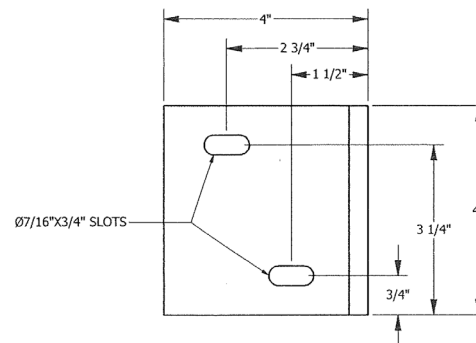

02 MOUNTING ANGLE DETAIL

UNLESS OTHERWISE SPECIFIED
 DIMENSIONS ARE IN INCHES.
 TOLERANCES
 .X=±.050
 .XX=±.015
 .XXX=±.005
 ANGULAR ±.5°

| | | | |
|----------|-----------|----------------------------------|----------|
| DRAWN | 9/16/2016 | RENLITA DOORS NORTH AMERICA, LLC | |
| DSF | | TITLE | |
| CHECKED | | S-1000 FLOATAWAY MIAMI-DADE | |
| QA | | SIZE | DWG NO |
| MFG | | C | 1K-MIAMI |
| APPROVED | | SCALE 1:1 | REV 3 |
| | | PAGE 9 OF 11 | |

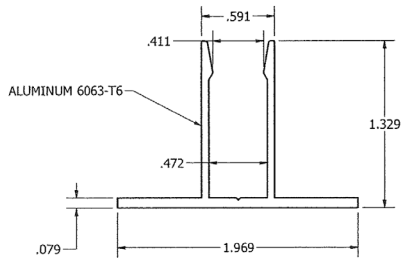

01 GLAZING BEAD (BASE)

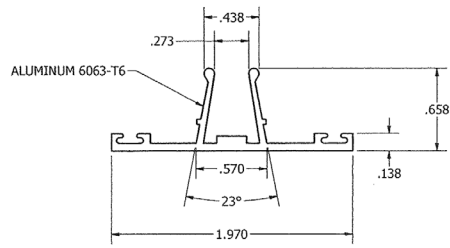

02 GLAZING BEAD (CAP)

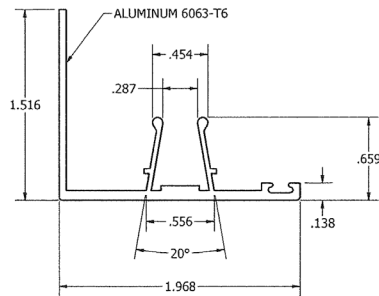

03 GLAZING BEAD (CORNER CAP)



FL. Cert. of Auth. # 8371
 1626 Ringling Boulevard, Suite 400
 Sarasota, FL 34236
 (941) 927-8525/ Fax (941) 927-8075
 John F Bonacci, PhD, PE
 FL. Registration # 63063

SEAL

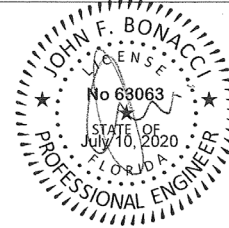

PRODUCT REVISED
 as complying with the Florida
 Building Code

NOA-No. **21-0504.05**

Expiration Date **08/27/2025**

By *Ishtay I. Chanin*
 Miami-Dade Product Control

PRODUCT REVISED
 as complying with the Florida
 Building Code

NOA-No. **24-1007.04**

Expiration Date **08/27/2025**

By *[Signature]*
 Miami-Dade Product Control

PRODUCT APPROVED
 as complying with the Florida
 Building Code

NOA-No. **20-0526.06**

Approval Date **08/27/2020**

By *[Signature]*
 Miami-Dade Product Control

UNLESS OTHERWISE SPECIFIED
 DIMENSIONS ARE IN INCHES.

TOLERANCES

.X=+.050
 .XX=+.015
 .XXX=+.005
 ANGULAR ±.5°

| | | | |
|----------|-----------|----------------------------------|---------------|
| DRAWN | 9/16/2016 | RENLITA DOORS NORTH AMERICA, LLC | |
| DSF | | TITLE | |
| CHECKED | | S-1000 FLOATAWAY MIAMI-DADE | |
| QA | | SIZE | DWG NO |
| MFG | | C | 1K-MIAMI |
| APPROVED | | SCALE 1:1 | PAGE 10 OF 11 |
| | | | REV 3 |

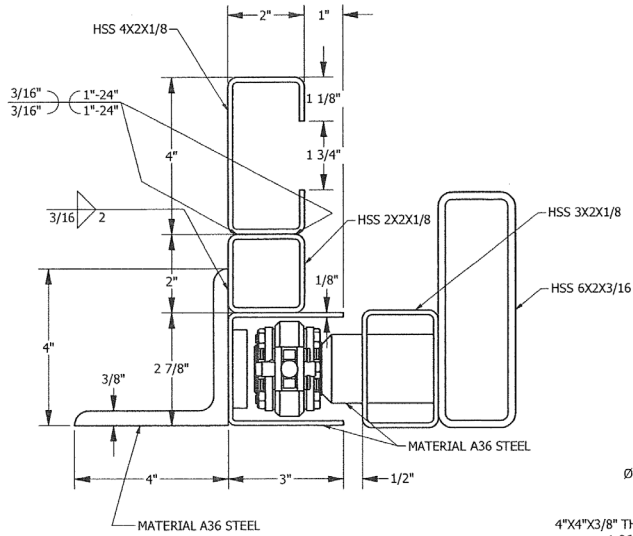

01 JAMB DETAIL TYP.

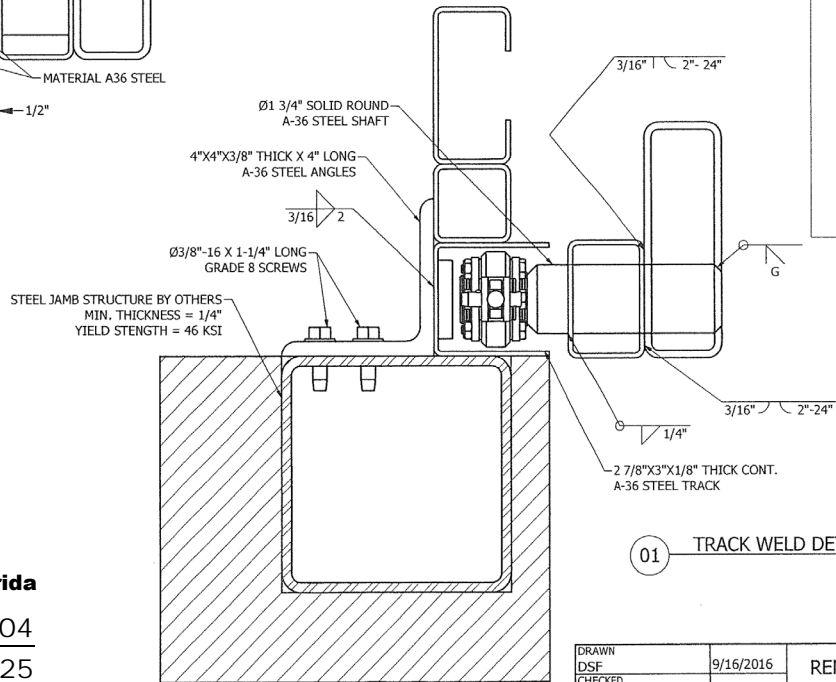

01 TRACK WELD DETAIL TYP.

PRODUCT REVISED
as complying with the Florida
Building Code

NOA-No. 24-1007.04

Expiration Date 08/27/2025

By *[Signature]*
Miami-Dade Product Control

UNLESS OTHERWISE SPECIFIED
DIMENSIONS ARE IN INCHES.
TOLERANCES
X=±.050
XX=±.015
XXX=±.005
ANGULAR ±.5°

| | | | |
|----------|-----------|----------------------------------|----------|
| DRAWN | 9/16/2016 | RENLITA DOORS NORTH AMERICA, LLC | |
| DSF | | TITLE | |
| CHECKED | | S-1000 FLOATAWAY MIAMI-DADE | |
| QA | | SIZE | DWG NO |
| MFG | | C | 1K-MIAMI |
| APPROVED | | SCALE 1:1 | REV 3 |
| | | PAGE 11 OF 11 | |



FL. Cert. of Auth. # 8371
1626 Ringling Boulevard, Suite 400
Sarasota, FL 34236
(941) 927-8525/ Fax (941) 927-8075
John F Bonacci, PhD, PE
FL. Registration # 63063

SEAL

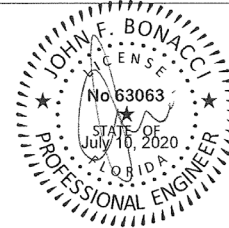

PRODUCT APPROVED
as complying with the Florida
Building Code
NOA-No. 20-0526.06

Approval Date 08/27/2020

By *[Signature]*
Miami-Dade Product Control

PRODUCT REVISED
as complying with the Florida
Building Code
NOA-No. 21-0504.05

Expiration Date 08/27/2025

By *[Signature]*
Miami-Dade Product Control